

OFFICE BUILDING AVAILABLE

5569 Houston Road * Macon, GA 31216



Sale Price: \$395,000
Lease Price: \$3,500/month NNN
(\$8.50 psf)

- Location:** Located in Middle Georgia's popular SubSouth area near intersection of Hartley Bridge Road and Houston Road intersection. Convenient to Robins Air Force Base, I-75 and Middle GA's other profile corridors.
- Property Description:** An office building with approximately 5,000 sf including 900 sf finished basement. Ideally located with abundant parking. Brick construction with Class A office finish.
- Signage:** Available signage on the Road and the building.
- Lot:** .60 Acre lot with 150' frontage on Houston Road.
- Nearby Businesses:** CVS Pharmacy, Family Dollar, Dollar General, Rutland Corners Apartments & Rutland Self Storage.
- Year Built:** 1994
- Taxes:** \$3,740 (2012)
- Insurance:** \$1,000 (EST)
- Traffic Count:** 9,940 VPD



Larry Crumbley
CCIM, CPM, SIOR
Cell: 478-737-3381
Email: lcrumbley@fickling.com
Web: www.lcrumbley.com

Commercial Division
577 Mulberry Street
Suite 1100
Macon, GA 31201
Phone: 478-746-9421
www.fickling.com

OFFICE BUILDING AVAILABLE

5569 Houston Road * Macon, GA 31216

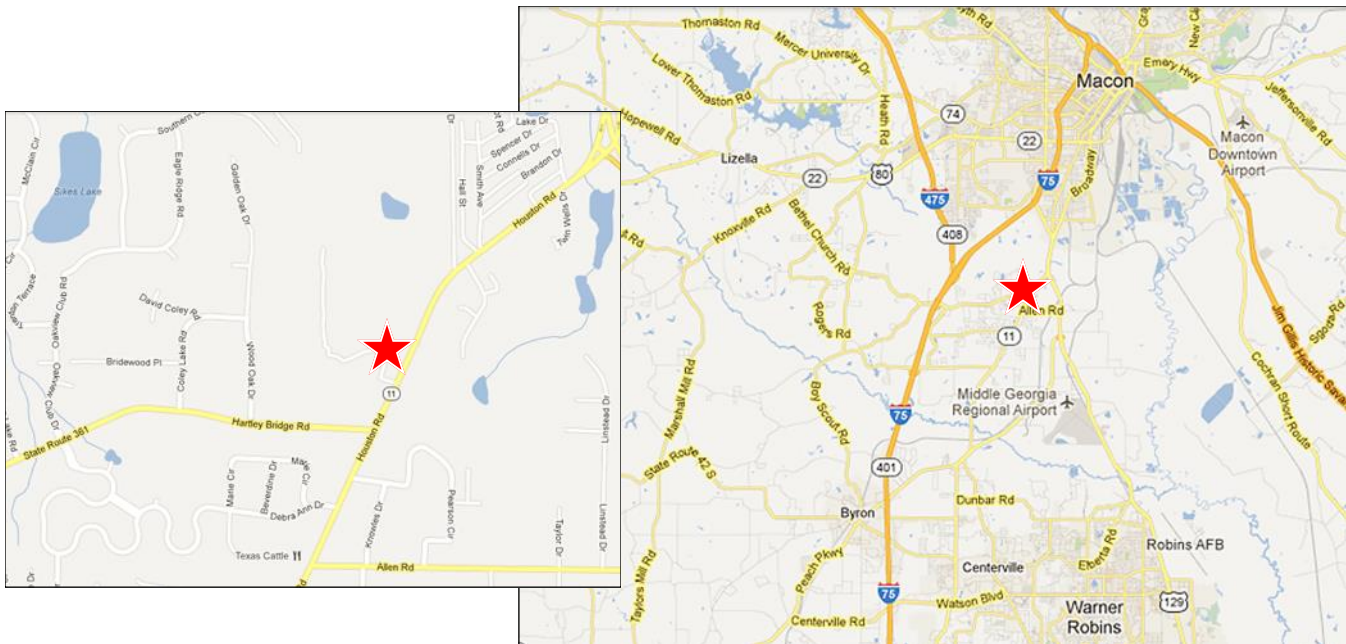

Larry Crumbley
CCIM, CPM, SIOR
Cell: 478-737-3381

Email: lcrumbley@fickling.com
Web: www.lcrumbley.com

Commercial Division
577 Mulberry Street
Suite 1100
Macon, GA 31201
Phone: 478-746-9421
www.fickling.com

This information is from resources deemed to be reliable, no warranties or guarantees for accuracy are made by Fickling and Company

OFFICE BUILDING AVAILABLE

5569 Houston Road * Macon, GA 31216

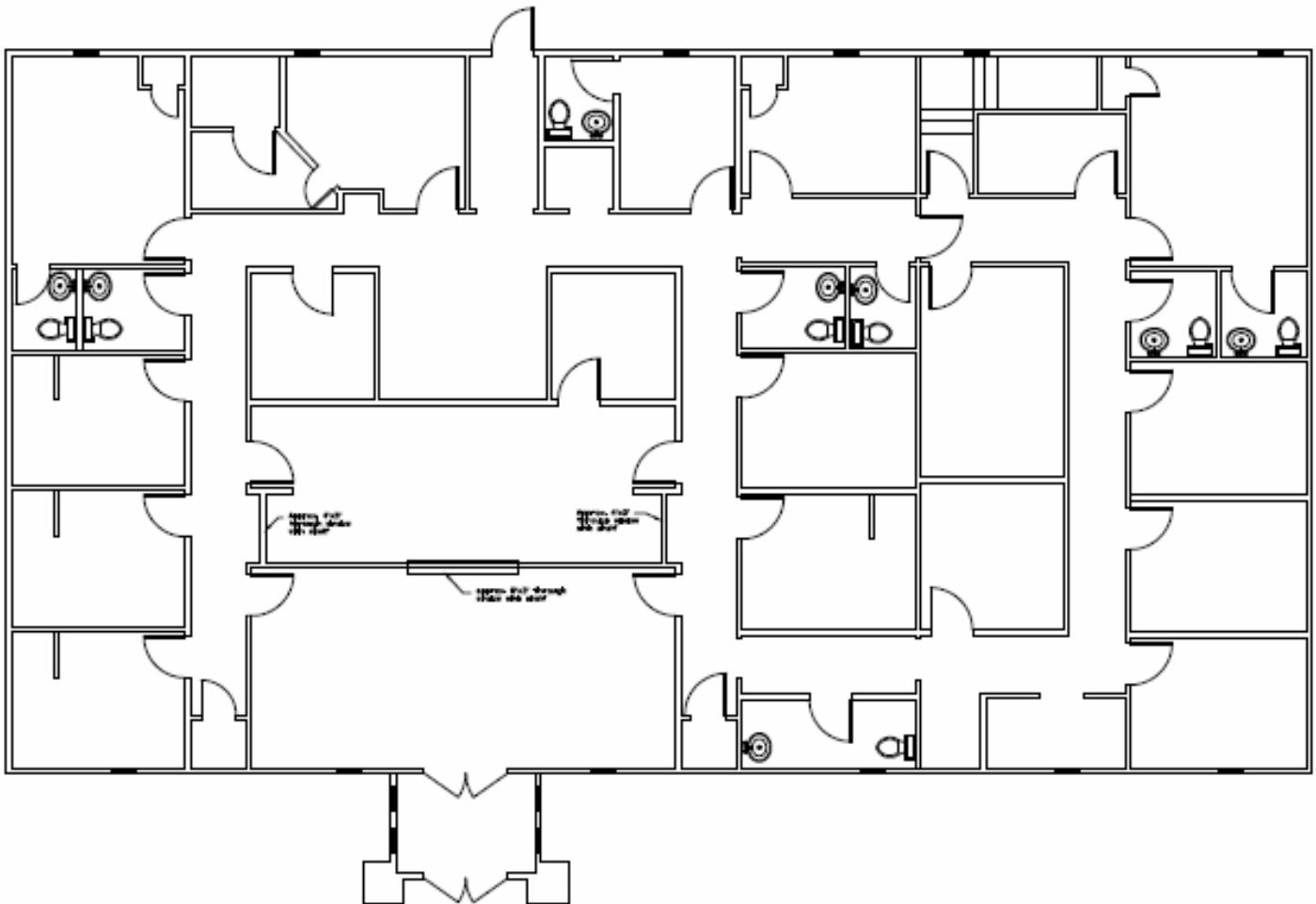
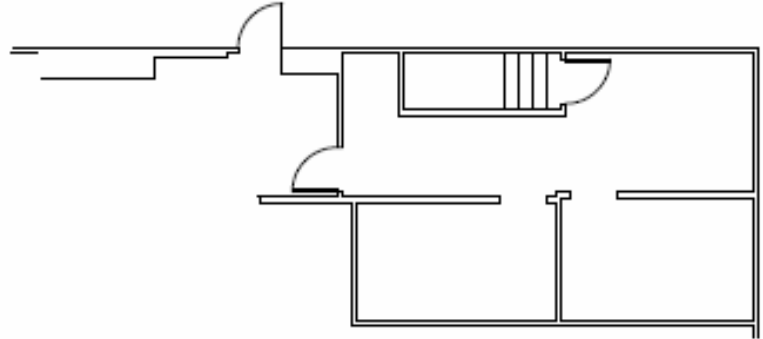

Larry Crumbley

CCIM, CPM, SIOR

Cell: 478-737-3381

Email: lcrumbley@fickling.com

Web: www.lcrumbley.com

Commercial Division

577 Mulberry Street

Suite 1100

Macon, GA 31201

Phone: 478-746-9421

www.fickling.com